

B

DIMENSIONS - MILLIMETERS (INCHES)

SUBSTITUTE

VARIABLE DISPLACEMENT VANE PUMPS		Graphic Symbol	Q max. (At 1800 r.p.m) lpm (USgpm)	P max. bar(PSI)	Speed r.p.m	Ref. Page
	PVF-12** -11		12(3.17)	70(1000)	Max.1800 Min.800	
	PVF-20** -11		20(5.28)			
	PVF-30** -11		30(7.93)			
	PVF-40** -11		40(10.57)			
	PVF-50** -11		50(13.21)			
	PVF-70** -11		70(18.49)			
	PVDF-2** -2** -11		20+20 (5.28+5.28)			
	PVDF-3** -3** -11		30+30 (7.93+7.93)			
	PVDF-4** -4** -11		40+40 (10.57+10.57)			
	PVDF-5** -5** -11		50+50 (13.21+13.21)			
	PVDF-7** -7** -11		70+70 (18.49+18.49)			
	VP5F-A* -50		30(7.93)	140(2000)		
	VP5F-B* -50		40(10.57)	70(1000)		
	VP6F-C* -50		54(14.27)	140(2000)		
	VP6F-D* -50		70(18.49)	70(1000)		
	VP7F-E* -50		120(31.70)	140(2000)		
	VP5FD-A* -A* -50		30+30 (7.93+7.93)	140(2000)		
	VP5FD-B* -B* -50		40+40 (10.57+10.57)	70(1000)		
	VP6FD-C* -C* -50		54+54 (14.27+14.27)	140(2000)		
	VP6FD-D* -D* -50		70+70 (18.49+18.49)	70(1000)		
	VP7FD-E* -E* -50		120+120 (31.70+31.70)	140(2000)		
Hi-Lo Pump  TPF	TPF-VL-30-GPH*		30(7.93)	LOW 70(1000)		
	TPF-VL-40-GPH*		40(10.57)	+		
	TPF-VL-50-GPH*		50(13.21)	HIGH 210(3000)		
	TPF-VL-70-GPH*		70(18.49)			

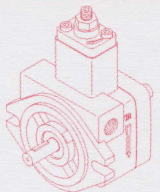
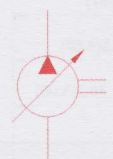
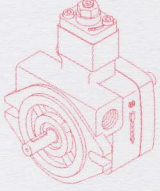
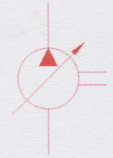
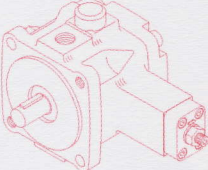
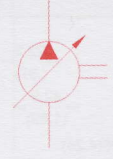
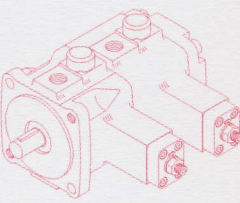
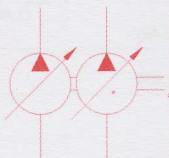
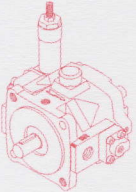
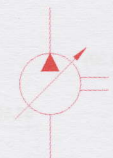
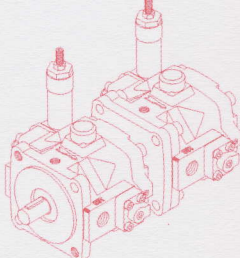
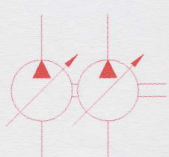
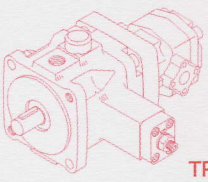
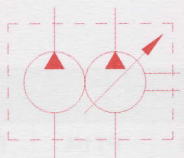
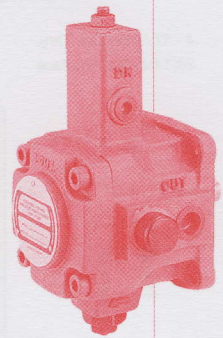



PVF-***

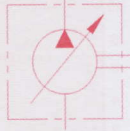
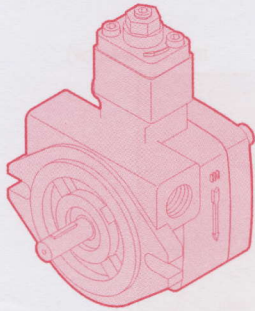

PVDF-**

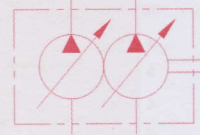
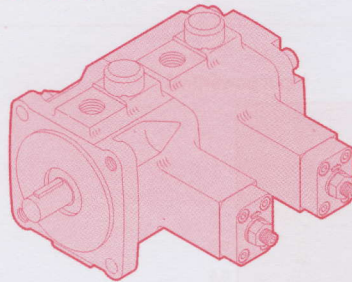

PVF Ordering Code - Single Pumps

PVF	-12		-70		-11
Series No.	Outlet flow at 3.5bar, 1800rpm lpm		Operating pressure range bar		Design No.
PVF Flange mounting	Code	Outlet flow	Code	Pressure range	
	12	12lpm	20	8~20bar	
	20	20lpm	35	15~35bar	
	30	30lpm	55	30~55bar	
	40	40lpm	70	50~70bar	
	Factory setting Qmax.		Factory setting Pmin.		

PVDF Ordering Code - Double Pumps

PVDF	-3		70		-3		70		-11
Series No,	Shaft end pump				Cover end pump				Design No.
	Outlet flow at 3.5bar, 1800rpm lpm		Operating pressure range bar		Outlet flow at 3.5bar, 1800rpm lpm		Operating pressure range bar		
PVDF Flange mounting	Code	Outlet flow	Code	Pressure range	Code	Outlet flow	Code	Pressure range	11:PT(Rc) 1180:PF(G) 1190:NPT
	3	30lpm	20	8~20bar	3	30lpm	20	8~20bar	
	4	40lpm	35	15~35bar	4	40lpm	35	15~35bar	
	Factory setting Qmax.		55	30~55bar	Factory setting Qmax.		55	30~55bar	
			70	50~70bar			70	50~70bar	
	Factory setting Pmin.				Factory setting Pmin.				

PVF/PVDF Pumps Speed Limits

Minimum speed: 800rpm
Maximum speed: 1800rpm

PVF/PVDF Pumps Weight

MODEL	Weight kg(ib)
PVF-12-**-11	5(11.01)
PVF-20-**-11	6(13.22)
PVF-30-**-11	9(19.82)
PVF-40-**-11	9(19.82)
PVDF-3**-3**-11	17(37.44)
PVDF-4**-4**-11	17(37.44)

PVF Series Pumps Curve

B

PVF-12-35-11

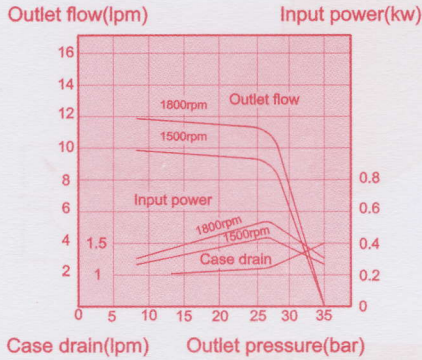

PVF-12-70-11

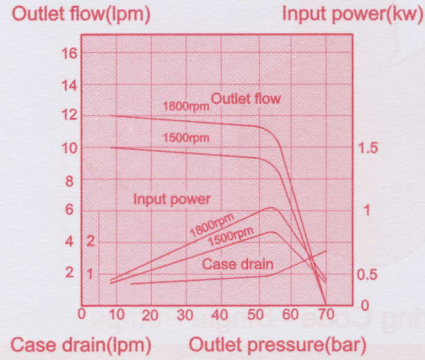

PVF-20-35-11

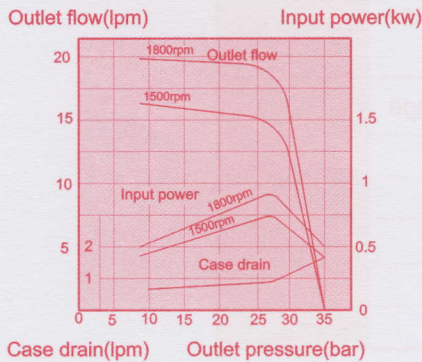

PVF-20-70-11

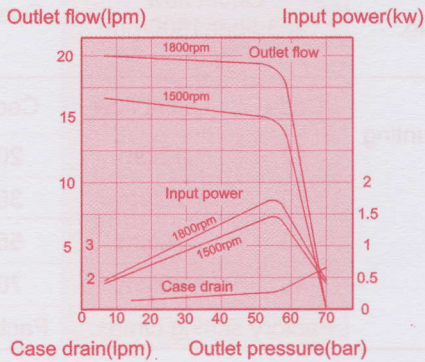

PVF-30-35-11

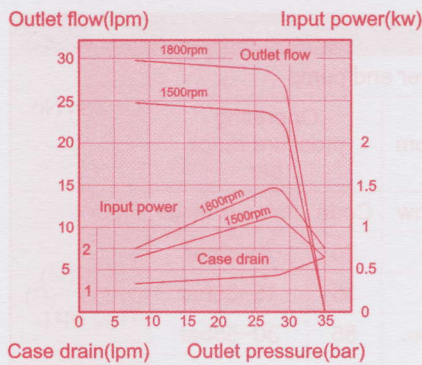

PVF-30-70-11

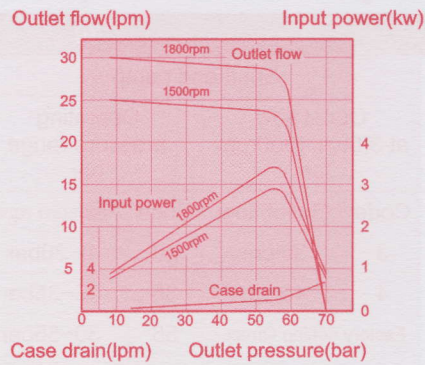

PVF-40-35-11

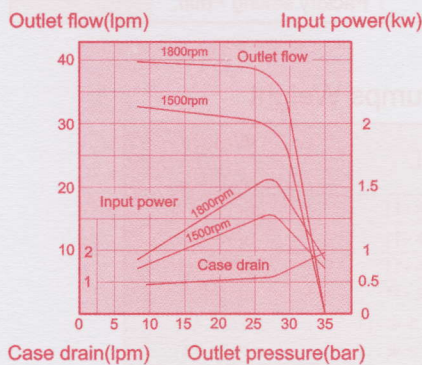

PVF-40-70-11

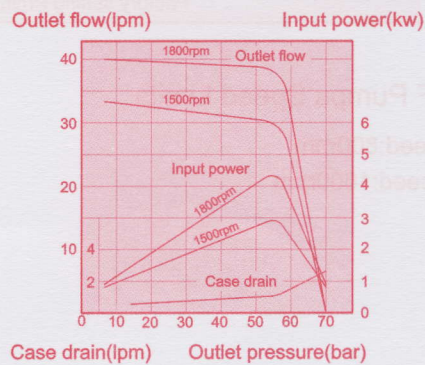



DIMENSIONS

MILLIMETERS(INCHES)

B

PVF-12-**-11

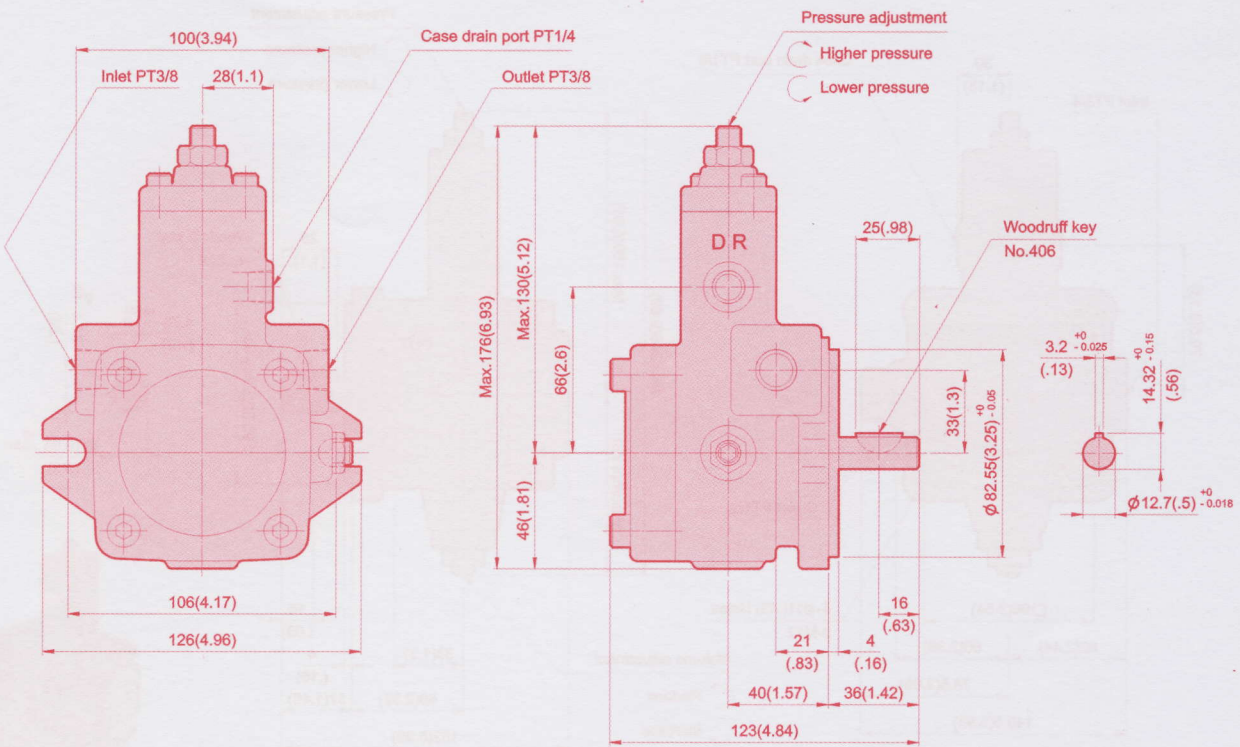

Note: Above type, without flow adjustment equipment.

PVF-20-**-11

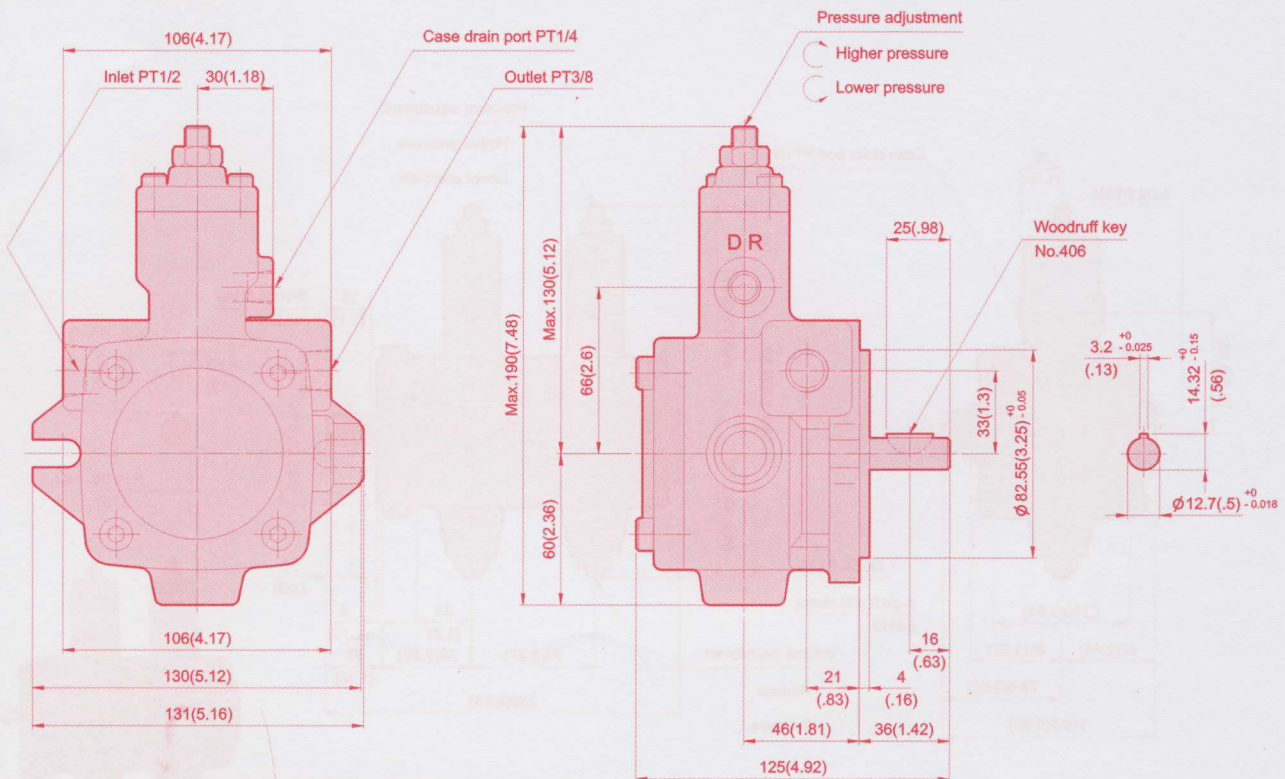

Note: Above type, without flow adjustment equipment.

DIMENSIONS

MILLIMETERS(INCHES)

PVF-30(40)-* *-11

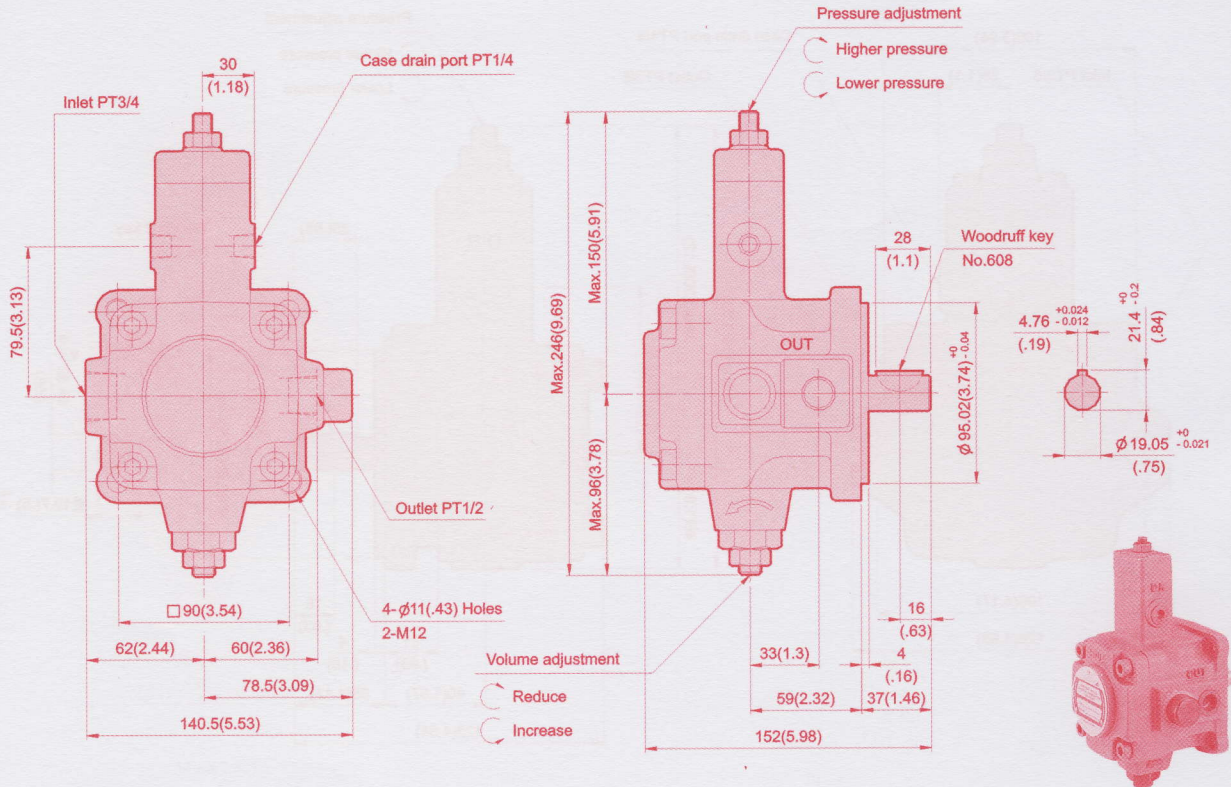

PVDF-*-***-11**

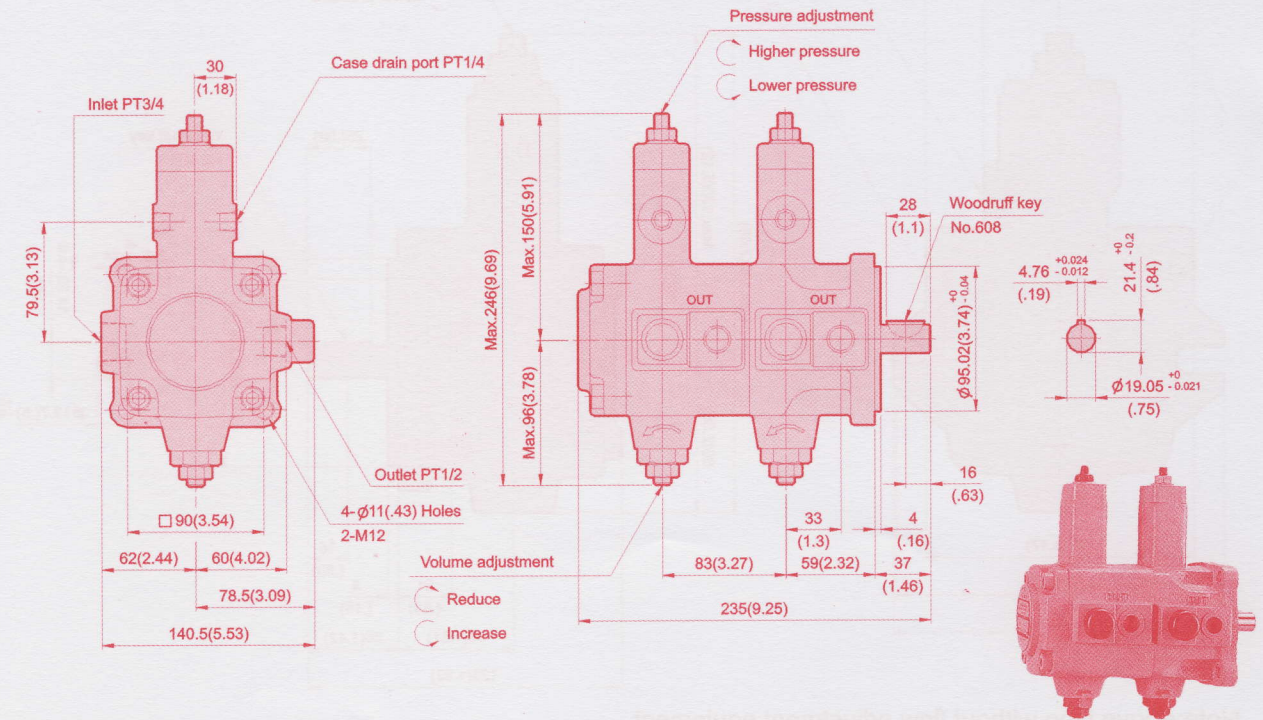



TPF-VL***-G00

TPF-VL***-GH*

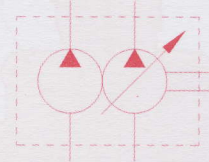
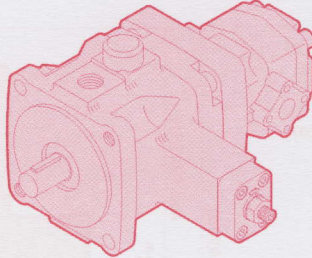
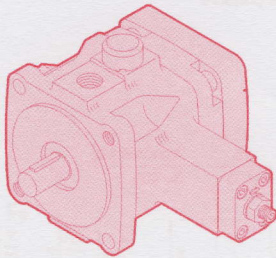

TPF Ordering Code - Hi-Lo Pumps

TPF	-VL30		2		-GH		2		-11
Series No.	Shaft end pump		Variable volume pressure compensated vane pump		Cover end pump		Fixed displacement gear pump		Design No.
	Outlet flow at 3.5bar, 1800rpm lpm		Operating pressure range bar		Displacement lpm		Operating pressure bar		
Flange mounting	Code	Outlet flow	Code	Pressure range	Code	Outlet flow	Pressure	Peak	11:PT(Rc) 1180:PF(G) 1190:NPT
	VL30	30lpm	1	15~35bar	GH1	1.09	210	250	
	VL40	40lpm	2	30~70bar	GH2	2.07			
	Factory setting Qmax.		Factory setting Pmin.		GH3	3.08			
					GH4	4.06			
					GH5	6.16			
					GH6	7.67			
					GH7	9.24			
					GH8	10.77			
					GH9	12.0			
				G00	G00 Type, is variable vane pump only, no including the gear pump.				

TPF Pumps Speed Limits

Minimum speed: 800rpm
Maximum speed: 1800rpm

TPF Pumps Weight

MODEL	Weight kg(ib)
TPF-VL***-G00-11	10(22.03)
TPF-VL***-GH*-11	11.7(25.77)

DIMENSIONS

MILLIMETERS(INCHES)

TPF-VL***-G00-11

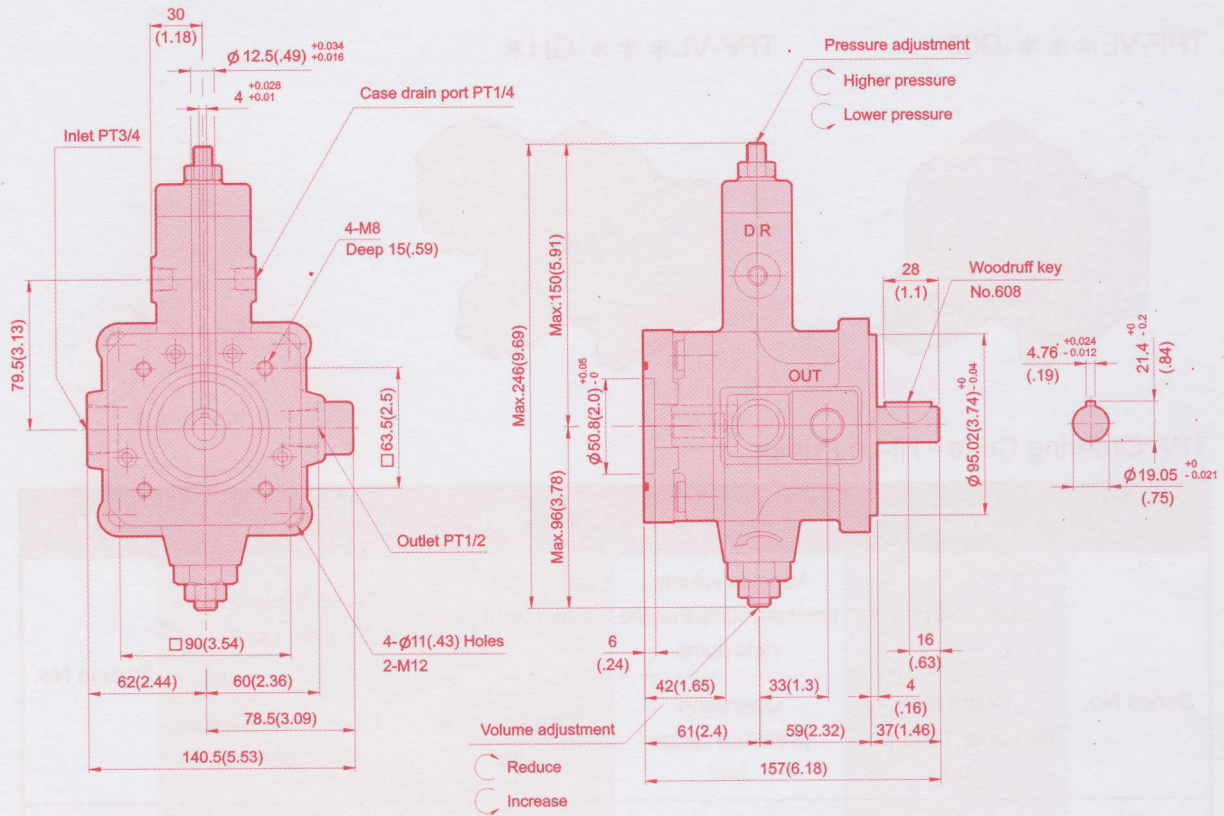

TPF-VL***-GH*-11

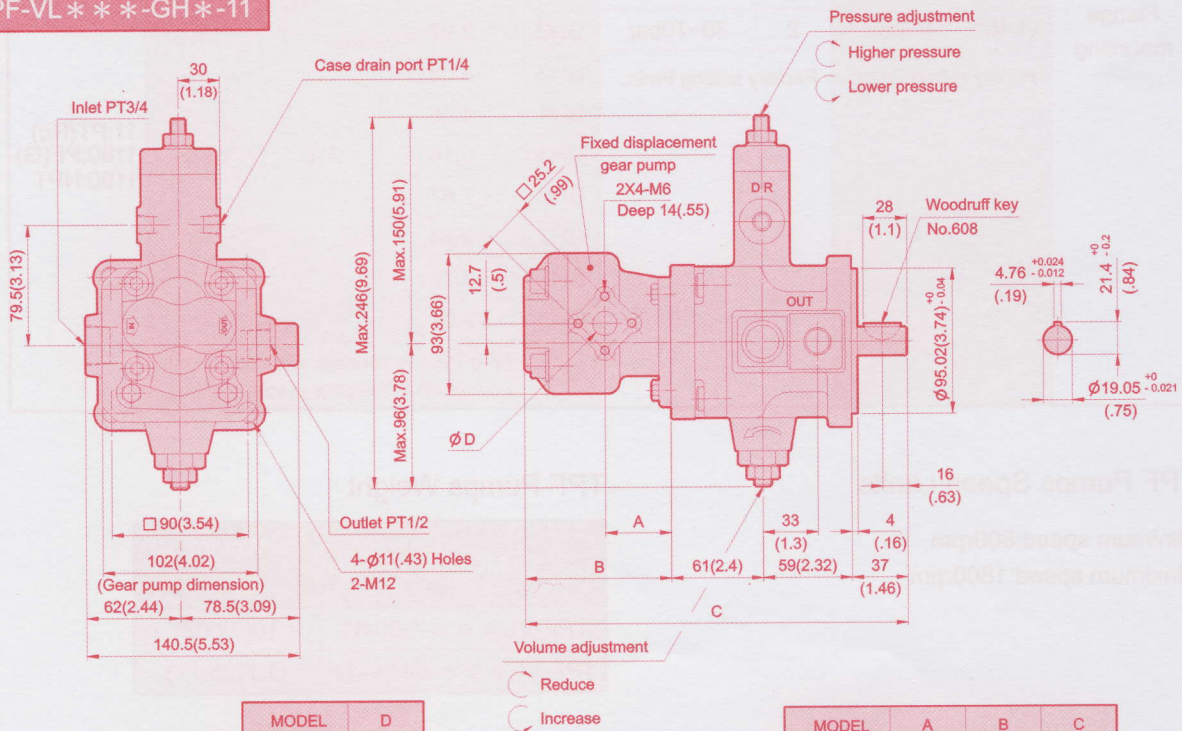

MODEL	D
GH1~GH4	14.8 (.58)
GH5~GH9	17.5 (.69)

MODEL	A	B	C
GH1~GH6	39.9 (1.57)	91.2 (3.59)	248.2 (9.77)
GH7~GH9	43.7 (1.72)	95 (3.74)	252 (9.92)



VP5F(D) Operating Data

VP5F

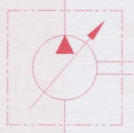
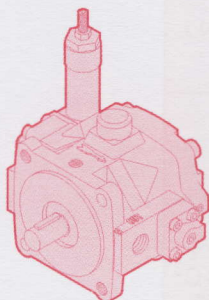

VP5FD

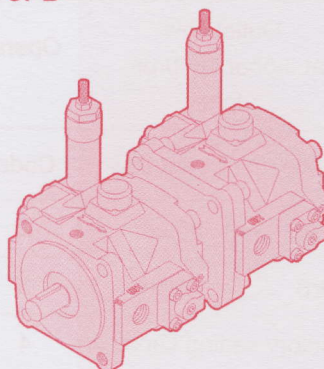

High Efficiency Operation With High Pressure.

Under the conditions of pressure 140 bar, the 5 pump is stable and highly efficient. Due to our improvement designs "THREE POINT RING" support systems.

No Vibration And Quiet.

The cam ring is specifically designed to have a special curve so the noise level (dB) is very low, even in the high pressure operations.

Sharp Characteristics And Quick Response.

Quick response displayed in both "ON-OFF" control of operation, due to use special design "BIAS PISTON" stable and accurate operation can be attained in an instant.

Stable Flow.

Due to use new design "PRESSURE BALANCE MECHANISM" the output flow pressure control systems, the output flow is very stable even in the high pressure ranges.

Energy Saving Type.

Power loss has been reduced further by application of our highly advanced precision machining technology to assure the same high efficiency performance. As the "VP5" series with many new mechanisms of our improvement designs. And the power loss at the "dead head" has been reduced by a large degree.

Easy Testing And Maintenance.

Pressure adjusting screw, and the volume adjusting screw were located at the same side, and ensure easy testing at a glance.

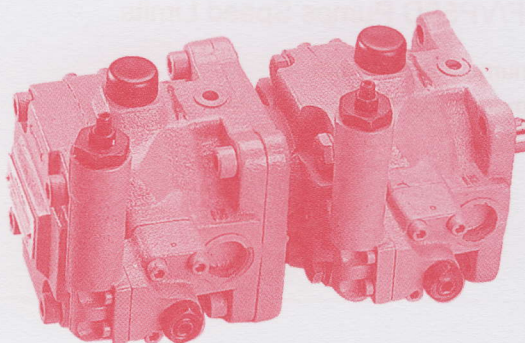
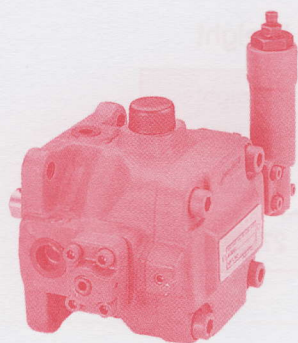

VP5F Ordering Code - Single Pumps

VP5F	-A		5		-50
Series No.	Outlet flow at 3.5bar, 1800rpm lpm		Operating pressure range bar		Design No.
VP5F Flange mounting	Code	Outlet flow	Code	Pressure range	50:PT(Rc) 5080:PF(G) 5090:NPT
	A	30lpm	2	15~35bar	
	★B	40lpm	3	20~70bar	
	Factory setting Qmax.		4	50~105bar	
			5	70~140bar	
		Factory setting Pmin.			

PS: ★ code B(40lpm), maximum pressure 70 bar.

VP5FD Ordering Code - Double Pumps

VP5FD	-A		5		-A		5		-50
Series No.	Shaft end pump				Cover end pump				Design No.
	Outlet flow at 3.5bar, 1800rpm lpm		Operating pressure range bar		Outlet flow at 3.5bar, 1800rpm lpm		Operating pressure range bar		
VP5FD Flange mounting	Code	Outlet flow	Code	Pressure range	Code	Outlet flow	Code	Pressure range	50:PT(Rc) 5080:PF(G) 5090:NPT
	A	30lpm	2	15~35bar	A	30 lpm	2	15~35bar	
	★B	40lpm	3	20~70bar	★B	40 lpm	3	20~70bar	
	Factory setting Qmax.		4	50~105bar	Factory setting Qmax.		4	50~105bar	
			5	70~140bar			5	70~140bar	
		Factory setting Pmin.					Factory setting Pmin.		

PS: ★ code B(40lpm), maximum pressure 70 bar.

VP5F/VP5FD Pumps Speed Limits

Minimum speed: 800rpm
Maximum speed: 1800rpm

VP5F/VP5FD Pumps Weight

MODEL	Weight kg(ib)
VP5F- * *-50	9.5(20.93)
VP5FD- * *- * *-50	27(59.47)



VP5F SERIES PUMPS CURVE

VP5F-A3-50

Outlet flow(lpm) Input power(kw)

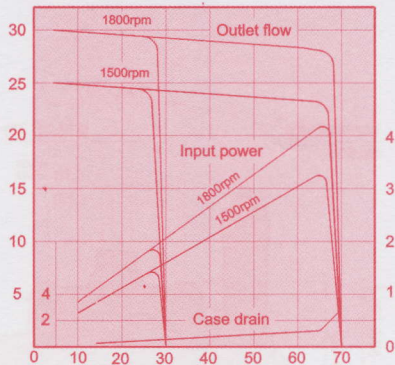

Case drain(lpm) Outlet pressure(bar)

VP5F-A5-50

Outlet flow(lpm) Input power(kw)

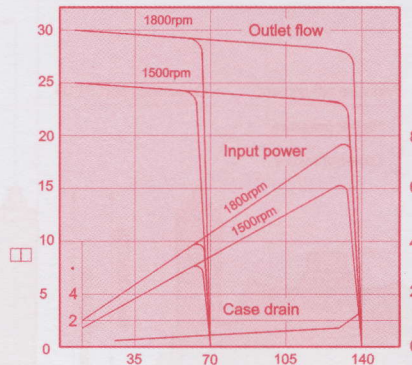

Case drain(lpm) Outlet pressure(bar)

VP5F-B3-50

Outlet flow(lpm) Input power(kw)

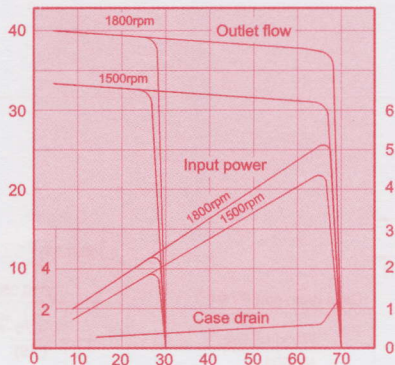

Case drain(lpm) Outlet pressure(bar)

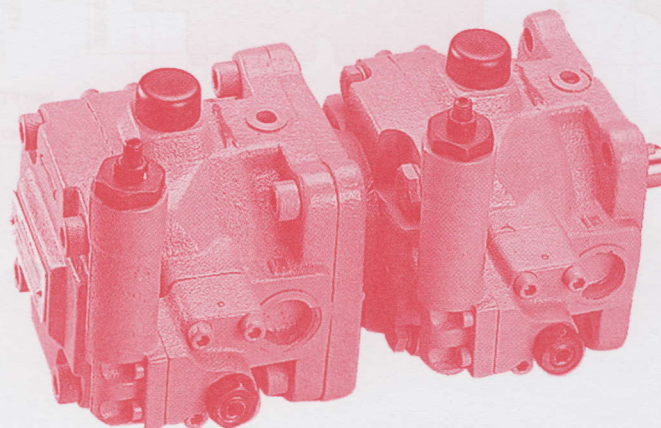
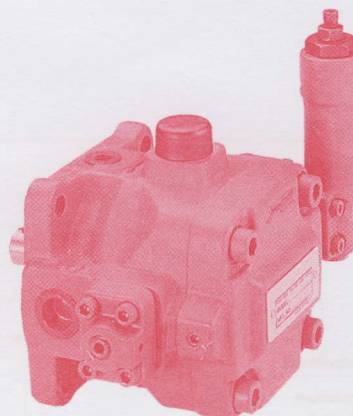

B

DIMENSIONS

MILLIMETERS(INCHES)

VP5F--50**

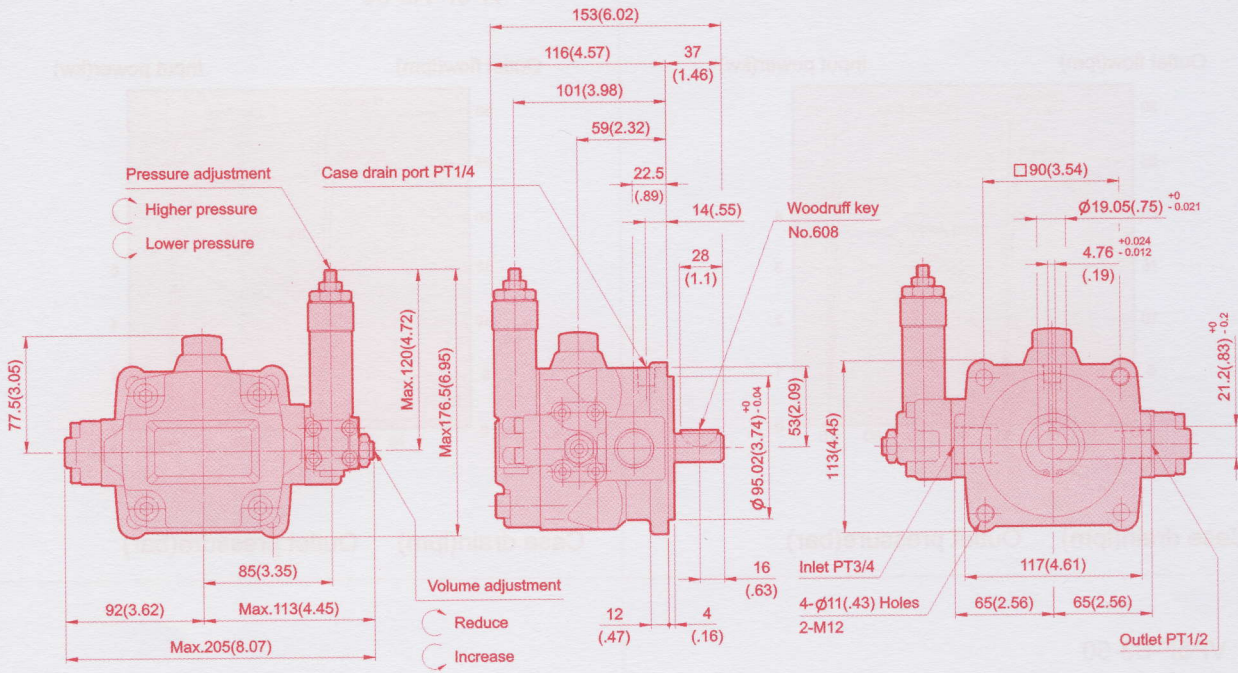

VP5FD--**-50**

